

MOSCA®

EXCELLENCE IN STRAPPING SOLUTIONS

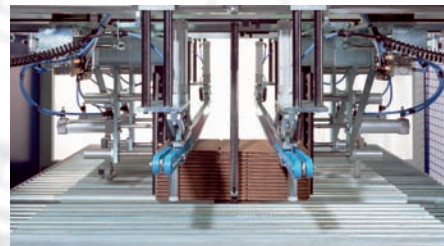

UATRI

Fully Automatic In-Line Corrugated
Cardboard Strapping Machine

UATRI

STANDARD FEATURES

- Height adjustable pneumatic top roller compression bar
- Quick release dispenser
- Integrated roller conveyor system
- Variable speed conveyor
- Thermostatically controlled heat-weld sealing system
- In-line strapping parallel to flute
- Selectable single or double parallel strapping mode with twin head model
- PLC control Siemens type S7
- Safety circuit for up-stream and down-stream systems
- Adjustable conveyor height 800 - 1050 mm as standard
- Structural coating RAL 5010 gentian blue
- Passage widths 1300 mm, 1600 mm or 2000 mm

FORMAT SET-UP:

- Fully automatic via touchscreen input
- 99 sizes can be stored

LATERAL MACHINE ALIGNMENT:

- Machine alignment to suit bundle conveyance
- Motorized rack and pinion drive system on floor mounted rails

EXACT BUNDLE SQUARING ON ALL SIDES BY:

- Backstops
- Longitudinal pusher
- Side pusher

OPTIONS:

- Air conditioner for control cabinet
- Signal exchange with upstream converting machine
- Upstream pacer conveyor
- MOSCA-QS-system
- Safety guard at infeed
- External data, automatic format setting based on server data / process data

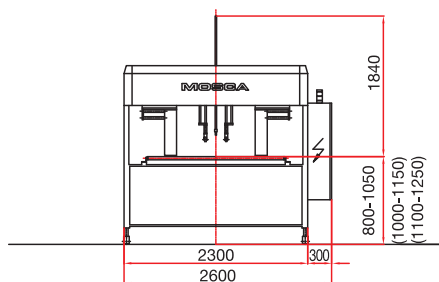

Technical drawing corresponds to UATRI 1300

TECHNICAL DATA

CAPACITY AT A CONVEYOR SPEED OF 1,6 M/S:

- Up to 30 single straps / minute
- Up to 30 parallel straps / minute with twin head model

STRAPPING:

5 - 9 mm PP straps

STRAP COIL DISPENSER:

Core Diameter: 200 mm
Core Width: 190 mm

ELECTRICAL POWER:

Voltage: 400 V (415, 440), 50/60 Hz, 3 PH
16 A CEE-plug approx. 5,1 kW
Power Consumption: approx. 5,1 kW

PNEUMATIC:

Operating Pressure: 6 bar
Air Consumption: approx. 20 l / Cycle

WEIGHT:	UATRI 1300	UATRI 1600	UATRI 2000
	2200kg	2500 kg	2800 kg

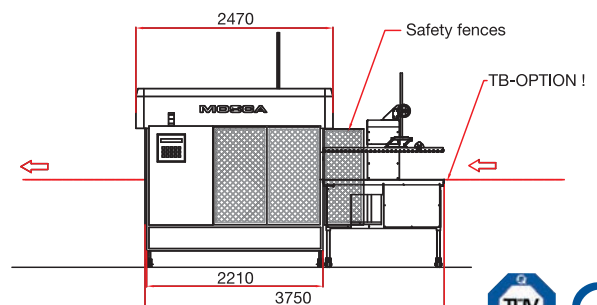
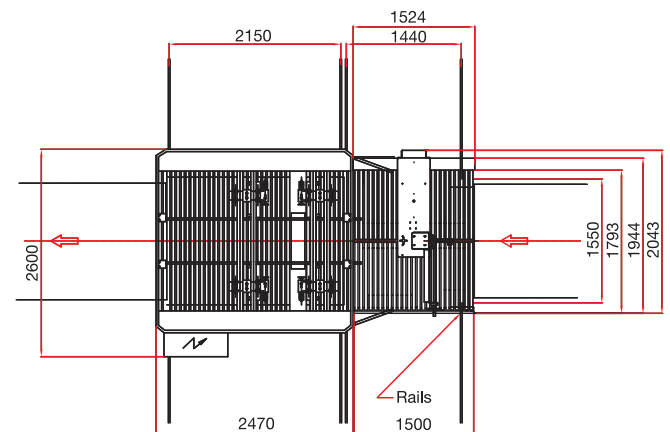

03 / 14 Subject to Alterations



MOSCA GMBH

Gerd-Mosca-Straße 1
D-69429 Waldbrunn/Germany
Tel.: +49 6274/932-0
Fax: +49 6274/932-400 118
Tel. Tech. Service: +49 6274 / 9 32-146
E-Mail: info@mosca.com
Internet: www.mosca.com

The models of UATRI are adjustable to one strap width of all quality PP straps between 5 and 9 mm. Obtainable directly from Mosca, produced in one of Europe's most modern manufacturing plants. Combinable with maintenance contracts by Mosca – a one-stop solution.

